



M60 Series

M60i	★★★	3 STAR
M60B, M60S	★★★★	4 STAR
M60G/GNZ	★★★★★	5 STAR

WITH BUILT-IN TURBO TIMER

OWNERS OPERATION MANUAL

includes programming and wiring information

All models certified to AS/NZS4601 amendment 1 2003
M60B/S also certified to AS/NZS3749.1 2003 Class B
M60G also certified to AS/NZS3749.1 2003 Class A & B

These products should be professionally installed according to the requirements of the AS/NZS 3749.2 1997 Installation Standard

REMOTE CONTROL

2 Supplied

BUTTON 'ONE'

ARM & DISARM

PRESS FOR 1 SECOND TO ARM OR DISARM THE SECURITY SYSTEM - (DOORS WILL ALSO LOCK OR UNLOCK IF THE CENTRAL LOCKING HAS BEEN CONNECTED)
FOR TURBO TIMER OPERATION SEE PAGE 6

BUTTON 'ONE' THEN BUTTON 'TWO'

'SENSOR BYPASS'

DEACTIVATES SENSORS SUCH AS THE IMPACT SENSOR.

ONLY DEACTIVATE SENSORS TO REDUCE THE POSSIBILITY OF FALSE ALARMS.



BUTTON 'TWO'

CHANNEL 2 OUTPUT (optional)

PRESS FOR 3 SECONDS FOR 'AUXILIARY OUTPUT'
EG: ELECTRIC BOOT RELEASE (if fitted)

PRESS WITH IGNITION ON TO TURN TURBO TIMER ON OR OFF

BUTTON 'TWO' THEN BUTTON 'ONE'

SILENT ARM / DISARM

THIS SEQUENCE WILL SILENTLY ARM OR DIS-ARM THE SYSTEM WITHOUT SIREN CHIRPS.
ALARM MODELS ONLY

BUTTON 'THREE'

'PANIC'

PRESS FOR 3 SECONDS TO SOUND THE SIREN OF THE ALARM. PRESS BOTH AGAIN TO CANCEL

BATTERY REPLACEMENT

YOUR REMOTE CONTROL USES 2 x CR2016 LITHIUM COIN BATTERIES WHICH ARE AVAILABLE FROM YOUR MONGOOSE AGENT OR ELECTRONIC SHOPS.

CONTENTS

Automatic engine immobilisation..	4	Noise pollution control.....	9
Arming & Disarming	5	Indicator flashing.....	10
Security re-arm	5	Dash mounted warning light...	10
Open circuit bypass.....	8	Chirp confirmation.....	10
Turbo timer.....	6	Panic.....	11
Security re-arm.....	6	Boot release.....	11
Silent arm/disarm	6	Programme options.....	11/12
Bonnet, boot & doors.....	6	Remote controls.....	13
2 stage impact sensor (M60B/S/G)	7	Remote code learning.....	13/14
Glass break sensor (M60G).....	7	EMERGENCY OVERRIDE.....	15
Ultrasonic sensors (accessory).....	7	Testing your alarm.....	16
Microwave sensor (accessory)....	8		
Sensor disable.....	8	Wiring & programming	
Intrusion alert.....	8	Warranty terms & conditions	
Battery back-up siren (M60S/G)...	8	Proof of purchase	
Automatic re-set.....	9		
Arm condition memory.....	9		

THE AUTOMATIC 'DUAL CIRCUIT' ENGINE IMMOBILISER

The engine will always be automatically immobilised 30 seconds after the ignition has been turned off.
(Unless the built-in turbo timer is enabled – see page 6)
This feature must not be turned off or defeated as it is an AS/NZS Standards or your insurance company requirement.

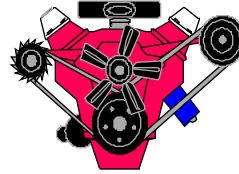

When the ignition is turned OFF, the dashboard LED will fast flash to indicate the automatic sequence has commenced. At the end of the 30 seconds, the siren will chirp once as confirmation of engine immobilisation. The indicators will also flash once and the dashboard LED will slow flash as further confirmation.

Only the engine is immobilised - the alarm system is not yet armed.
If an attempt is then made to start the engine whilst immobilised, the siren will chirp continuously when the ignition is on. It stops chirping when the ignition is turned off.

ONCE IMMOBILISED, PRESS BUTTON ONE ON THE REMOTE CONTROL TO PERMIT ENGINE STARTING

NOTE: If you fully arm the alarm by pressing the remote button, the engine is immobilised immediately and any attempt to start the engine will cause the siren to sound fully.

The installer of this system will immobilise two of the following possible circuits to prevent engine starting (current draw per circuit must not exceed a maximum 10amps continuous);

- Starter motor
- Ignition system
- Electric fuel pump
- Other engine controlling circuit

ARMING

- ❑ Exit the vehicle and close all the doors (& bonnet & boot).
- ❑ Press button **one** on the remote control.
The indicators flash once and the siren will chirp once to indicate that the system is armed.
The dash board warning light, LED, will slow flash to indicate the system is armed.
- ❑ If your vehicle has central locking and it has been connected to this security system, the doors will lock at the same time as arming.

NOTE: If the engine has automatically immobilised before you had the opportunity to fully arm the system, press button one twice – once to deactivate the immobiliser and the second time to fully arm and immobilise the security system.

DISARMING

- ❑ Press button **one** on the remote control to disarm the system.
The siren will chirp twice and the indicators will flash twice to indicate disarming.
- ❑ The doors will unlock if connected to the security system.
- ❑ If a door is not opened within 30 seconds, the system will automatically re-arm (& re-lock if connected to your central locking) . See below.
- ❑ If your remote fails to disarm the security system for any reason, you can disarm the system by using the PIN override code.

AUTOMATIC SECURITY RE-ARM

The alarm will automatically fully re-arm (and re-lock the doors if connected) if it has been disarmed by remote but a door has not been opened within 30 seconds. The engine will re-immobilise if the engine is not started within 30 seconds.

BUILT-IN TURBO TIMER OPERATION

The built-in turbo timer allows the engine to continue running for a pre-programmed time after the ignition has been turned off. This feature may be used to allow the vehicles turbo to cool down if excessively hot. In normal driving situations, the turbo timer should not be necessary.

The timer is programmable for duration from 1 to 5 minutes - see 'programming'.

To enable the turbo timer feature:- with the ignition on, press button 2 on the remote, siren chirps once. The timer function will now always be ON each time the vehicle is used.

To disable the timer, repeat the above procedure – siren chirps twice – timer is now off.

NOTE: When the engine is running, arming the alarm does not immediately immobilise the engine or turn on any sensors. An intrusion by opening any door, bonnet or boot will immediately stop and immobilise the engine and trigger the alarm.

To arm with timer ON:-

- Ensure the vehicle is in neutral gear or 'park' position and the handbrake is applied.
- Turn the ignition off (engine remains running if timer is ON – engine stops if timer is OFF)
- Exit the vehicle ensuring all doors, bonnet & boot are closed.
- Arm the alarm by remote as normal.
- After the programmed time, the engine stops with the immobilisers engaged and any sensors arm after a 10 second delay to allow for any residual engine vibration.

CAUTIONS ON USING THE TURBO TIMER

1. When people or animals are still inside the vehicle
2. When doors or windows are to be left open
3. If you require immediate full security protection
4. To save fuel
5. Is prohibited by country or state laws or by any other authority.
6. When doing so is likely to cause a risk or danger to others or property
7. When re-fuelling

OPEN CIRCUIT BYPASS

If any door, the bonnet or boot is left open upon arming, the siren will chirp once as normal and then sound briefly to inform you a circuit is still open. If ignored, that circuit will not be protected.

The open circuit (a door, the bonnet or boot) will automatically arm upon closure.

INTRUSION ALERT

When disarming, if the siren chirps 4 times and the indicators flash 3 times you know the system has been triggered. Refer to the LED flash codes on page 10 to show which circuit has been triggered.

AUTOMATIC RE-SET

Upon an intrusion, the siren will sound for 30 seconds, after which it will stop and reset to the armed position. It will then re-trigger on the next intrusion or, for example, if a door is left open.

If a door is left open, the siren will sound for 3 x 30 seconds and then that circuit will be bypassed.

NOISE POLLUTION CONTROL

To reduce noise nuisance and possible false alarms, the system will isolate an individual circuit if it is triggered three times in succession or is left open. (Eg: 3 x bonnet/boot, 3 x doors, 3 x ignition, 3 x sensor). Reset by remote by disarming and then re-arming, or by turning the ignition 'on' then 'off'.

CENTRAL LOCKING - additional parts, at extra cost, may be required depending on vehicle equipment level.

This security system has built-in relays to operate a vehicles' existing central locking system by remote control. When connected, the doors will lock or unlock at the same time as arming or disarming.

SILENT ARM / DISARM (no siren chirps – alarm models only)

If there is occasion when you don't want the siren to chirp for either arm or disarm, press button **two** then button **one** within 2 seconds. The chirps may be permanently turned off via the programming options.

SENSOR DISABLE BY REMOTE (alarm models only)

There are times when you may wish to deactivate sensors (such as the impact sensor) to prevent false alarms. To turn sensors off, but still arm the rest of the system, press button one to arm the system and within 3 seconds, press button two. You will hear the siren chirp for arming followed by three tones indicating the sensors are turned off for this time only. To disable the sensors at some later time after arming, press the 2nd button three times quickly. If the alarm is sounding and has been triggered by a sensor, pressing the 2nd button disables the sensor from further detections.

PANIC BY REMOTE (in either armed or disarmed state)

In the event of personal attack or you suspect that your vehicle is being tampered with, the alarm can be 'panicked' by pressing button three on the remote for more than 3 seconds. The siren will sound and the indicators will flash. Press button one to cancel alarm sounding.

IGNITION, BONNET, BOOT & DOORS

When armed, the siren will sound and the indicators will flash for 30 seconds when any of these are triggered. If a door, the bonnet or boot is left open, the siren will cycle 90 seconds (3 x 30 seconds) and the indicators will flash. (If programmed for NSW, the siren will sound for 30 seconds once only) The system does require your vehicle to be fitted with courtesy light door switches for these to trigger the alarm. Fitting or replacing door switches will incur additional charges.

CHANNEL 2 OUTPUT (eg: BOOT RELEASE – OPTIONAL CONNECTION)

The system provides an output to control features such as a vehicle's electric boot release if the vehicle is equipped (a boot release conversion kit is available as an accessory). This may incur additional charges depending on the vehicle specification.

To activate:

- Press button two on the remote for 3 seconds and the boot will unlock and open
- The boot trigger circuit and any interior sensor will be bypassed
- Upon closing the boot the bypassed circuits will re-arm automatically

GLASS BREAK SENSOR (M60G MODELS – optional on other models)

This sensor is designed to trigger the alarm by detecting the sound of actual glass breakage. The sensitivity level is set by the installer and should be at its optimum.

2 STAGE IMPACT SENSOR (MODELS M60B/S/G)

This sensor is designed to detect impacts to the vehicle. It should not be triggered by normal wind, or rocking motions.

- If the sensor detects a light impact, the siren will sound a few warning chirps.
- If the sensor detects a heavier impact, the siren will sound fully and the lights will flash for 30 seconds.

The sensor is adjustable for sensitivity and is set by the installer.

(This type of sensor may not detect the theft of wheels, we therefore advise the fitment of locking wheel nuts and our self levelling electronic tilt sensor)

BATTERY BACK-UP SIREN (M60S/G – optional on other models)

Vehicle battery disconnection or cutting the siren wires will cause the battery back-up siren to sound independently of an alarm trigger. The siren can be turned off with the special keys provided. You should turn the siren off whenever the car battery needs attention or changing.

CAUTION: Check that the siren has been mounted in such a position so as to avoid water ingress or heat damage. If washing the engine bay, cover the siren with a plastic bag to prevent water damage. Heat or water damage is not covered by the warranty.

ARM CONDITION MEMORY

Should the vehicle battery be disconnected, the system memorises the last set position of the alarm. If the battery was disconnected whilst the system was armed, reconnection will return the system to the armed state and may trigger the siren.

ALARM CHIRP CONFIRMATION & CODES

- a) 1 Chirp - Armed.
- b) 1 Chirp/short siren - indicates an open circuit when arming.
- c) 2 Chirps - Disarmed.
- d) 4 Chirps - Disarmed and indicates that the alarm has been triggered.
- e) Continual chirps - Ignition has been turned on when the engine is immobilised

INDICATOR FLASHING (FUSE PROTECTED)

When the siren sounds, the indicators flash simultaneously.

The indicators will also flash on arming and disarming the system.

- a) 1 Flash - Armed.
- b) 2 Flash - Disarmed.
- c) 3 Flash - Disarmed and previously triggered.

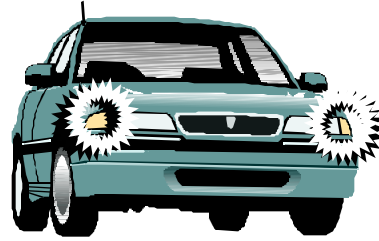

DASH MOUNTED WARNING LIGHT – LED

The LED shows the status of the alarm, intrusion and any open circuit when arming.

Turning the ignition 'on' resets the flash codes.

- a) Fast flashing - 30 second countdown for automatic functions.
- b) Slow flashing - system armed.
- c) LED off - system disarmed and ignition on.
- d) On permanently - in remote code learning mode
- e) 1 flash - bonnet or boot has been opened.
- f) 2 flash - a sensor has been triggered.
- g) 3 flash - a door has been opened.
- h) 4 flash - an engine start was attempted.



ULTRASONIC SENSOR (optional)

The ultrasonic sensor fill the interior of your vehicle with high frequency sound and is designed to trigger the alarm when the interior environment changes. Possible changes are the breaking or removal of glass, a door being opened, or even strong wind through a slightly open window.

For the ultrasonic sensor to operate correctly ensure all doors and windows are closed when arming the alarm system. (False alarms are generally created by open windows or even strong wind through the air vents)

Due to the efficiency of this type of sensor, we advise that you do not leave people or animals inside the vehicle as any movement will trigger the alarm. Should you need to leave people or animals inside, follow the instructions for 'sensor disable by remote' to avoid the alarm being triggered.

Ultrasonic's are not recommended for soft top vehicles or vehicles where air movement is likely within the vehicle.

MICROWAVE SENSOR (optional)

The microwave sensor is designed to trigger the alarm when a microwave field registers physical movement. 2 fields are generated, one outside the vehicle to give perimeter protection, and one inside to give interior protection.

Intrusion into the perimeter area chirps the siren as a warning, whilst intrusion into the interior fully sounds the siren. The fields are adjustable for size and should have been set by the installer at their optimum. It is advisable to limit the exterior field to about the width of the door mirrors and the interior to approximately $\frac{3}{4}$ of the vehicle width. Do not leave people or animals inside the vehicle as any movement will trigger the alarm. Should you need to leave people or animals inside when arming, follow the instructions for 'sensor disable by remote'.

Note: As the microwave produces circular protective fields, some areas of large vehicles may not be protected.

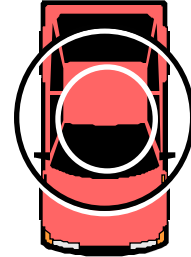

PROGRAMME OPTIONS

AUTOMATIC (LAST DOOR) ARMING - PROGRAMMABLE

This feature is factory set in the 'off' position. You may have this programmed 'on' for added security. The alarm will then arm automatically 30 seconds after the last door is closed.

- The doors will not lock so that keys cannot be locked inside
- If the engine immobilises prior to the opening and closing of a door, this feature is bypassed. Press button one to unset the immobiliser and press again to arm the system.
- The opening of a door, bonnet or boot during the 30 seconds will suspend the countdown and recommence on closure.

IGNITION SAFETY DOOR LOCK - PROGRAMMABLE

If the system has been connected to a vehicles' central locking, the doors will lock 3 seconds after the ignition is switched 'on' and unlock when the ignition is turned 'off'.

If a door is left open for more than 3 seconds after the ignition has been turned on the safety door lock feature will be inoperative.

SIREN CHIRPS - PROGRAMMABLE

The arm/disarm chirps can be permanently turned off. The indicators confirm the arming and disarming. The siren will still chirp for automatic functions.

TURBO TIMER – PROGRAMMABLE

The built-in turbo timer is programmable for duration from 1 to 5 minutes.

TURBO INTERFACE FUNCTION – PROGRAMMABLE

This allows an engine to remain running from an aftermarket turbo timer if the built-in timer is not required. When the turbo timer stops, the immobilisers and any alarm sensors become active after a 10 second delay. An intrusion through the doors whilst the engine is running will immediately immobilise the engine (all models) and sound the alarm (alarm models only).

ROLLING CODE REMOTE CONTROLS

Two remote controls are supplied with the system which enable you to arm and disarm your security system. One remote control should be kept with your car keys and the other with your spare car keys in a safe place. We do not recommend leaving the spare remote and car keys in the vehicle.

The remote security code of your alarm system changes each time you press the remote button. This coding system is referred to as Rolling Code, or Random Encryption, therefore eliminating the possibility of anyone recording it (code grabbing).

The batteries in the remote controls should be changed annually or when you notice any of the following;

- System does not respond to the remote signal (see below)
- Operation is intermittent
- Reduced operating range – less than 5 metres
- The LED fails to light

Replace with 2 x CR2016 lithium batteries.

If, for some reason, the security system does not disarm by the remote control, use the PIN code to override the system – see page 15.

REMOTE CONTROL 'CODE LEARNING'

The main alarm module has a learning capacity to memorise up to four remote controls.

If you wish to add further remotes, or a remote has to be replaced, the new remote needs to be code learnt into the main module. If you have lost a remote, it should be deleted from memory so it cannot be used.

An irregular or interruption to the vehicle's power supply may cause the remote not to work due to loss of remote memory. If your alarm fails to respond to the remote try re-learning them (may require the system to be overridden using the PIN code), or see your Mongoose dealer for assistance.

TO LEARN REMOTE CONTROLS

- ❑ Disarm the system
- ❑ Drivers door must be open
- ❑ Turn the ignition ON/OFF 3 times (ignition remains off)
- ❑ The siren will chirp 3 times, the indicators will flash 3 times and the dashboard LED will light permanently to confirm you have entered remote code learning mode.
- ❑ Press button one on the 1st remote – siren will chirp once as confirmation of reception
- ❑ Press button one on the 2nd remote – siren will chirp twice as confirmation of reception
- ❑ Repeat for up to four remotes (siren will chirp 3 times for the 3rd and 4 times for the 4th)
- ❑ Leave the system for 10 seconds and the learning mode is completed. This is confirmed by three fast chirps and light flashes.

NOTE: When learning a new replacement or additional remote, the original remote(s) must be re-learnt or they will be erased from memory and will not operate this system.

To delete a lost remote from memory:

Re-learn the existing remote as detailed above. The lost remote is now deleted and will not operate the security system. When a replacement is obtained, learn both the existing and new remote into memory as detailed above.

EMERGENCY OVERRIDE

DO NOT LOSE THIS CARD – KEEP IN A SECURE PLACE

Record the PIN on the 'proof of purchase' and in your mobile phone.
The system can be disarmed by entering the unique code shown on the 'PIN Code Card' issued with this product.
Following is an example using PIN code **4525**

Note: If your PIN code contains a "0", this equals '10' flashes.

The code is entered by turning the ignition ON or OFF in sequence with the dash mounted LED.

- 1) **Ignition ON** - LED will light permanently to commence override.
- 2) **Ignition OFF** - LED will start flashing. Count the number of flashes for the first number.
- 3) **Ignition ON** - after 4 flashes (1st number of the example). The LED will light.
- 4) **Ignition OFF** - count the number of flashes.
- 5) **Ignition ON** - after 5 flashes (2nd number). The LED will light.
- 6) **Ignition OFF** - count the number of flashes.
- 7) **Ignition ON** - after 2 flashes (3rd number). The LED will light.
- 8) **Ignition OFF** - count the number of flashes.
- 9) **Ignition ON** - after 5 flashes (4th number).
- 10) **The system will now disarm and the vehicle can be started.**

Should you enter a digit incorrectly, wait for 11 flashes and repeat the procedure from step 1).



TESTING YOUR ALARM

We recommend frequent testing to ensure correct operation.

- Without disarming the system, unlock and open a door with the ignition key - the alarm should sound, excluding immobiliser model M60i. Check all other doors, bonnet and boot by the same procedure.
- Check the impact sensor, M60B/S/G, by giving the vehicle varying degrees of impact - be careful to do this on areas of the vehicle not likely to be damaged by impact. Light impacts should chirp the siren whilst heavier impacts should fully sound the siren.
- Check the glass break sensor, M60G, by tapping the glass with a coin. Varying degrees of tapping should be tried to see the level of sensitivity. Be careful not to break the glass.
- To test the engine immobilisers, enter the vehicle and shut all doors, arm the system by remote and try to start the engine - it should not start and the siren (if fitted) should sound.
- To test the optional ultrasonic sensors, leave a window open when arming. Wait say 20 seconds to allow the sensor to stabilise. Through the open window wave your arms inside the vehicle – the alarm should sound.
- To test the optional microwave sensor, arm the system and wait at least 10~20 seconds for the sensor to stabilise. Moving a hand over the outside of the side windows should chirp the siren a few times. How close you have to get to the vehicle tells you the exterior field size.
- To test the interior, leave a window open when arming and reach in and wave an arm around the siren should fully sound. How far you have to reach in tells you the interior field size.

WIRING INFORMATION: Installation to be carried out by suitably qualified persons.

MAIN MODULE The wires are printed for the function – remove labels when connecting:

- | | | |
|-----------|---------------|---|
| 1) | – TRIG | (-) BONNET & BOOT TRIGGER INPUT |
| 2) | CH2 | (-) CH 2 OUTPUT – EG: BOOT RELEASE |
| 3) | IGN | (+) 12v IGNITION INPUT |
| 4) | GND ARM | (-) GROUND WHEN ARMED OUTPUT |
| 5) | DOOR | (-) DOOR TRIGGER – jumper changes polarity |
| 6) | NO CONNECTION | |
| 10) | FLASHER | (+) INDICATOR OUTPUT – 8 amp cont' max |
| 11) | 12V | (+) CONSTANT 12v POWER SUPPLY |
| 12) | FLASHER | (+) INDICATOR OUTPUT – 8 amp cont' max |
| 13) & 14) | GND | (-) 2 GROUNDS – <u>DO NOT JOIN TOGETHER AT THE SAME POINT</u> |
| 15) | SIREN | (+) SIREN / HORN OUTPUT |
| 7) | PURPLE | LOCK – NO |
| 8) | ORANGE | UNLOCK – NO |
| 9) | BLUE | UNLOCK – COMMON |
| 16) | WHITE | LOCK - NC |
| 17) | BROWN | UNLOCK - NC |
| 18) | GREEN | LOCK - COMMON NOT USED |
| | IM01 | IMMOBILISER CIRCUIT #1 – PAIRED WIRES – max 10amp cont' |
| | IM02 | IMMOBILISER CIRCUIT #2 – PAIRED WIRES – max 10 amp cont' |

SIREN / BONNET LOOM – BULLET CONNECTED
ALL BLACK WIRING – PRINTED WITH FUNCTION

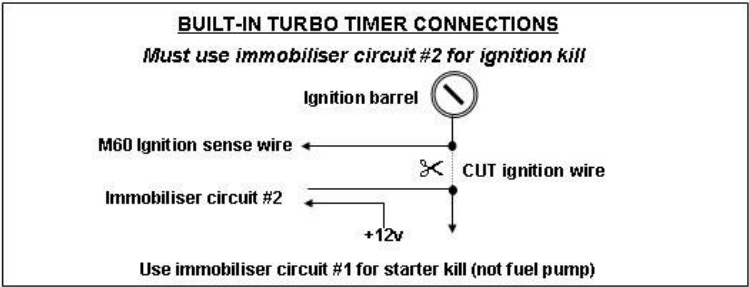
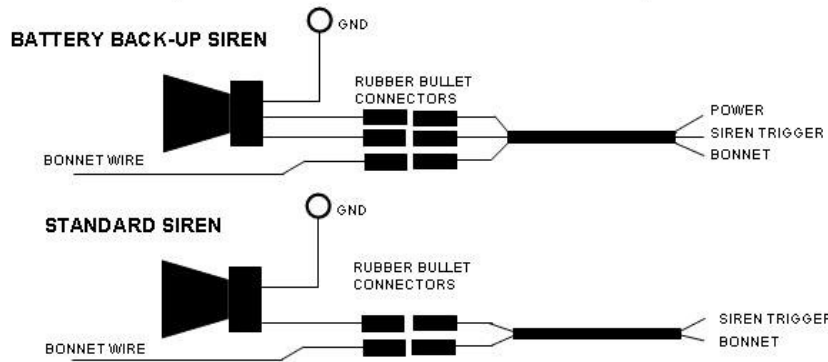

CENTRAL LOCKING CONNECTION OPTIONS

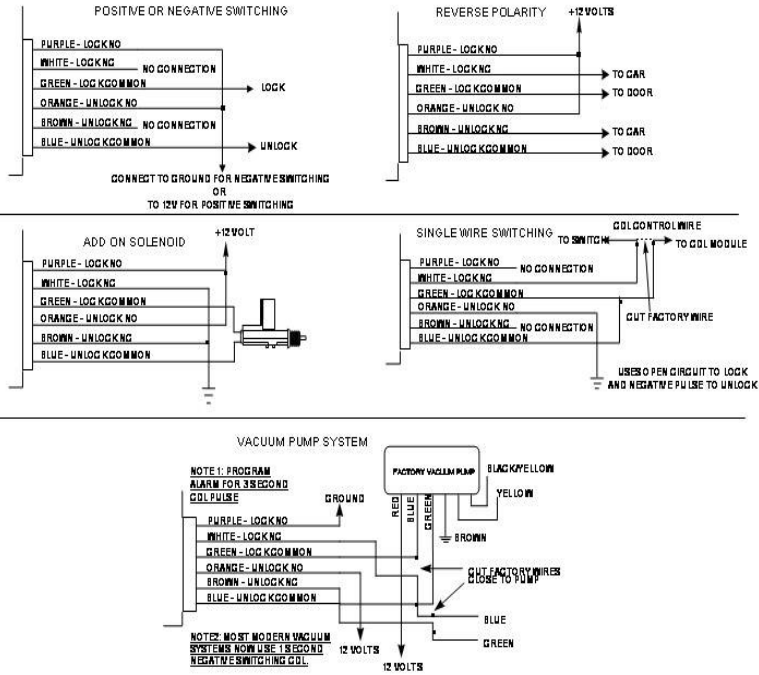

PROGRAMMING

1. Drivers door must be open
2. Within 15 seconds of opening the door, turn the ignition ON/OFF the number of times relative to the programme chart (eg: 4 times for ignition door locking)
3. Siren will then chirp the same number of times as the programme number (eg: 4 times for ignition door locking), the lights also flash the same number of times
4. Press button one to turn the feature "ON" - siren chirps once – lights flash once
Press button two to turn feature "OFF" - siren chirps twice – lights flash twice
5. Leave system for 10 seconds - system fast chirps 3 times (lights flash 3 times) to signify end of programming

* = DEFAULT

	FEATURE	BUTTON ONE (ON)	BUTTON TWO (OFF)
3	REMOTE CODE LEARNING		
4	IGNITION DOOR LOCK	ON	OFF*
5	SIREN CHIRPS	ON	OFF
6	TURBO TIMER	Each press = 1 minute Siren chirps for minutes set (max' 5 mins – 5 chirps)	N/A
7	LAST DOOR ARMING	ON	OFF *
8	DOOR DIAGNOSTICS	ON *	OFF
9	ENGINE IMMOBILISER	ON*	OFF
10	SIREN OR HORN	SIREN *	HORN
11	CDL PULSE	0.8 SEC'	3.5 Sec.
12	NSW SIREN TIMING	ON	OFF *

Interface for external aftermarket turbo timer - remove jumper J2. If using built-in timer – do not remove

WARRANTY CONDITIONS

PRODUCT WARRANTY

Mongoose warrants for a period of 36 months that it will make good without charge at Mongoose's discretion, by repair or replacement with a reasonable equivalent, any defect in the product providing that;

- (a) the defect has been notified as soon as it is noticed to an authorised Mongoose installation centre, distributor or agent (in the first instance to the original installation centre).
- (b) the alarm is less than 3 years of age from the date of sale and was manufactured within the last 4 years.
- (c) the alarm has been installed by an approved Mongoose installation agent
- (d) it has been installed according to the AS/NZS 3749.2 Installation Standards and/or to our written instructions.
- (e) provision of proof of purchase stating where it was purchased and by whom it was installed.
- (e) if the alarm is installed by anyone other than an approved Mongoose installer a 12 month **parts only** warranty applies
- (f) an authorised installation centre has determined that the defect complained of is a genuine product defect and not caused by;
 - (i) incorrect installation or any other consequential damage caused by the vehicle or other vehicle parts
 - (ii) operation of alarm after it is known to be defective
 - (iii) alteration or modification of the alarm or its components
 - (iv) the fitment of additional security parts or accessories not supplied by or approved of by Mongoose
 - (v) any work carried out on the alarm by someone other than an authorised Mongoose installation centre
 - (vi) misuse, accident, deliberate act or abuse (eg: misdirected electrical current, ingress of water or fluid, vehicle damage)

Exclusions:

- (i) removal & refitting costs of parts
- (ii) mobile service costs
- (iii) batteries, i.e. remote controls
- (iv) normal wear and tear
- (v) alarms operated outside the original country of purchase
- (vi) freight costs of parts to rectification centres
- (vii) transport costs of getting a vehicle to a repair centre
- (viii) consequential costs of vehicle non-operation where the remote controls or PIN code card are lost, not available, or an inability to use

INSTALLATION WARRANTY

Warranty for the installation is borne by the original installing agent only.

The period and terms of warranty are determined by the installation agent and should be verified with them.

Rectification work required to correct an installation fault carried out by anyone other than the original installation agent will incur their charges.

Authorisation to have this work carried out and agreement to have any costs refunded should be obtained from the original installation agent prior to work commencing.

Whilst every care is taken in fitting the security system, Mongoose accepts no responsibility for any damage caused to a vehicle in the installation process. Responsibility is borne by the installer.

THIS WARRANTY IS ONLY TRANSFERABLE AS PRESCRIBED AS BELOW

- a) If the vehicle is sold complete with this product together with an original 'proof of purchase', the new owner receives the balance of any warranty period remaining. If 'proof of purchase' is not provided, then this warranty ceases on change of vehicle ownership.
- b) If the original owner has the system re-installed into an alternative vehicle by an authorised Mongoose installation centre, the owner receives the remaining period of warranty. If re-installed by an unauthorised person, this warranty ceases.



All models certified to AS/NZS4601 amendment 1 2003
M60B/S also certified to AS/NZS3749.1 2003 Class B
M60G also certified to AS/NZS3749.1 2003 Class A & B

Manufactured for: Mongoose (Australia) Pty Ltd
Make & Model Number: Mongoose M60 Series
Country of manufacture: Taiwan R.O.C.
Supply voltage: 12v DC nominal – negative ground
Current consumption: 0.3amps (see alarm module label)
Suitability: All vehicles with 12v negative earth batteries
Date of manufacture: Refer date code on alarm module case

AS/NZS3749.1 2003 Class A/B definition: includes control equipment including setting and un-setting facilities, all sensors, warning devices and provision for engine immobilisation of the vehicle.

Whilst this security system provides a deterrent, it may not prevent theft or damage through wilful criminal intent. Mongoose does not by inference, intent or any other means guarantee that a vehicle fitted with one of its security systems will not be stolen, broken into, tampered with, or parts taken. Mongoose does not offer nor will pay compensation for any loss. We recommend adequate vehicle insurance and the fitment of other security devices as deemed necessary. The loss and any associated costs of replacing the remote controls and/or PIN code card in making the vehicle mobile are the responsibility of the vehicle owner/driver.

PROOF OF PURCHASE
DO NOT LEAVE THIS INFORMATION IN THE VEHICLE

OWNERS NAME:..... VEHICLE MAKE:.....
ADDRESS:..... VEHICLE MODEL:.....
..... VEHICLE REG' NO:.....
TELEPHONE NO:..... ALARM MODEL NO:.....
ALARM PURCHASED FROM:..... **OVERRIDE PIN NUMBER:**.....
DATE PURCHASED:.....
INSTALLED BY:.....
DATE INSTALLED:.....
INSTALLER SIGNATURE:.....
OWNERS SIGNATURE:.....

Dealer stamp

Please complete the above details which should be presented to your Mongoose dealer in the event that you require this product to be repaired under the terms of the 'product warranty'. Refer 'Warranty Conditions'. Failure to provide this 'Proof of Purchase' may result in rectification charges being made. If you sell the vehicle complete with this product within the warranty term, please pass on this on to the new owner – failure to do so will result in this warranty ceasing.